

## FF600 Retractor Systems - Track Applications

### SECURE THE WHEELCHAIR

#### Position the Wheelchair

Position the wheelchair and occupant facing forward as shown in Figure 1. The wheelchair tie-downs need approximately a 45° angle from the floor anchor system to where they attach to the wheelchair. Apply the wheelchair hand brakes and turn off power on motorized wheelchairs.

#### Install the Rear Retractors

Rear retractor tie-downs have a D-ring for attachment of the occupant restraint. Locate and install rear retractors into the floor anchor system 12" to 18" apart, between the rear wheels of the wheelchair. See Figure 1. Pull on fitting to ensure it is properly locked in the floor anchor system and keeper is facing away from wheelchair. Retractor systems with 4 identical retractors and D-rings may be installed in any position. Position retractors for best access to tensioning handles.

#### Install the Front Retractors

Locate and install the front retractors in the floor anchor system 3" to 8" outside of front wheels. See Figure 1. Pull on fitting to ensure it is properly locked in the floor anchor system and keeper is facing away from wheelchair. Position retractors for best access to the tensioning handles.

#### Attach to Wheelchair

Starting with the rear retractors, push the red release lever of the retractor and pull out the webbing. Release lever and loop the tie-down end around a structural member of the chair. Insert the connector plate into buckle and ensure that it has fully engaged into the buckle by pulling on the tie-down. If your retractor is equipped with an S-hook, place it securely around a structural member of the chair. Pull on the S-hook to ensure full engagement around the structural member. Push the retractor release lever until loose webbing is retracted. Repeat procedure for other retractors. Tension the front or rear retractors as needed by turning the handles until the tie-downs are tight.

**Caution: Do not attach tie-downs to the wheels or any detachable portion of the wheelchair. Tie-down must have a clear, straight path from floor to where it attaches to the wheelchair. Do not allow tie-downs to conform or bend around any object, i.e. the wheels or foot rests. Keep tie-downs away from sharp edges or corners.**

### Restrain the Occupant

#### Attach the Combination Lap/Shoulder Belt

Grasp the buckle connector and pull the webbing out of the retractor. While holding onto the sidewall snap hook, slide the buckle connector up the webbing a full arms' length. See Figure 2.

Grasp the snap hook on the retractable belt (this will install on the side of the occupant that is closest to vehicle sidewall) and thread it down and through the gap between the wheelchair back and seat or side panel and seat. Connect the snap hook to the D-ring on the rear retractor tie-down as shown in Figure 1.

Grasp the snap hook on the push-button buckle belt (this will install on the side of the occupant that is closest to the aisle) and thread it down and through the gap between the wheelchair back and seat or between the side panel and seat. Connect the snap hook to the D-ring on the aisle side rear retractor tie-down as shown in Figure 1.

#### Tension the Lap Belt

Insert the buckle connector into the push-button buckle. Tension the buckle connector belt comfortably using the web adjuster. Ensure that the lap belt is worn low across the front of the pelvis, bearing upon the bony structure of the body and that the push-button buckle is located near the occupant's hip opposite of the side from where the shoulder belt is anchored. Pull on the lap belt to ensure proper attachment. See Figure 3.

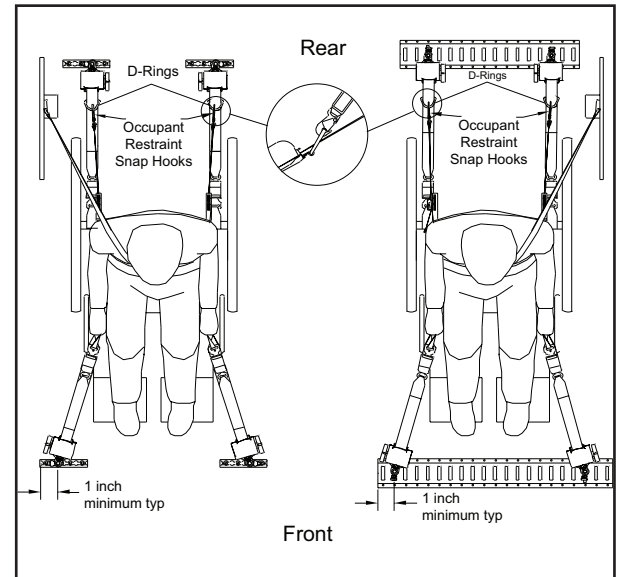

Figure 1

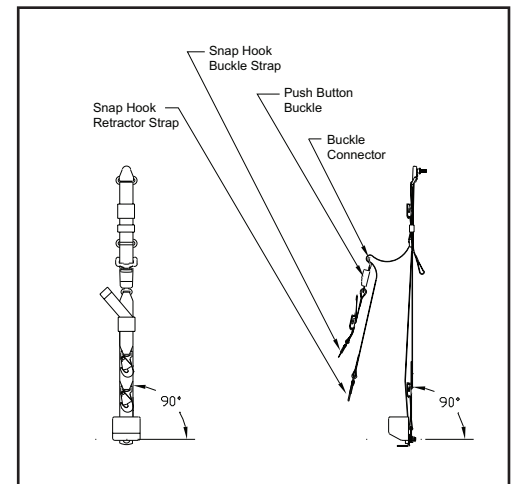

Figure 2

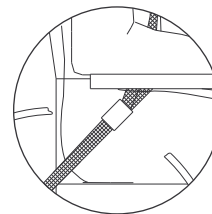

Figure 3

**SURE-LOK**

Safe and Secure

2501 Baglyos Circle  
Bethlehem, PA 18020-8027  
Phone: (866) 787-3565  
Fax: (866) 843-3696  
www.sure-lok.com

**Cautions: Always ensure that the shoulder belt is properly extended over the shoulder and across the upper torso of the occupant. Never extend the shoulder belt across the neck.**

**When connecting the shoulder belt to the lap belt, always ensure that the push-button buckle and buckle connector are located at the occupant's hip opposite of the vehicle sidewall where the shoulder belt anchorage is installed. Ensure that the lap belt buckle is located in such a way that it is clear and is not in contact with any of the wheelchair components or any structures during operation as to minimize any potential contact during its use or in case of an accident.**

**Never place the lap belt over the wheelchair arm rests and side panels or above the occupant's abdominal area.**

**Adjust occupant restraints as firmly as possible consistent with user comfort. Do not twist webbing. Protect webbing from sharp edges and corners.**



**Note:** This information is not all inclusive and may not cover or represent every installation. For additional product information, refer to the current Sure-Lok Catalog, the instructions included with each Retractor kit or contact Sure-Lok, Inc.